

Rare Earth Magnetic Separator System

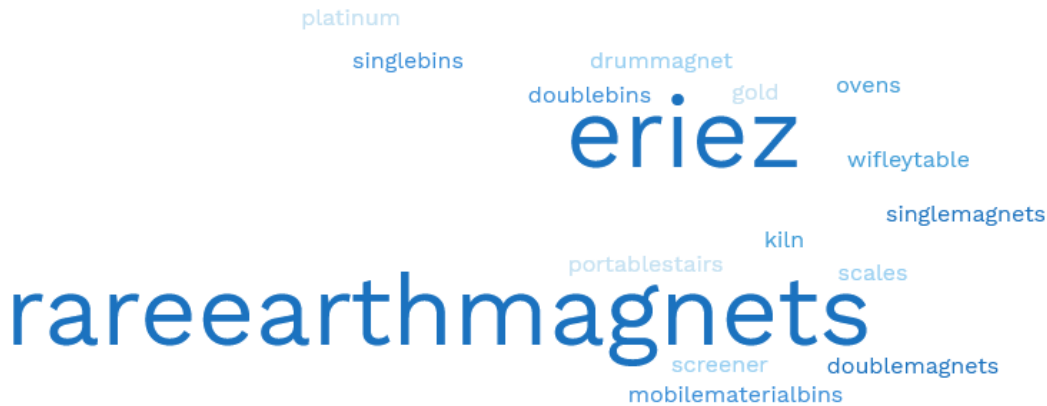

Complete Magnetic Separator System (Used)

Ready for your operation to extract various end user products such as magnetics/iron ore for the purification or concentration of weakly magnetic materials including the recovery of Rare Earth materials. Recovery of materials is completed by passing the material over a magnetic drum to separate iron ores from sand, dirt, rock and other nonspecific materials to access the Rare Earth materials.

Can also be used for the purification of non-magnetic materials such as plastics, food and pharmaceutical, glass, and recycling.

History

This Eriez magnetic separator system was developed and used in a pilot project to process the by-products of crushed granite rock using a dry process. We were able to recover 14 out of 17 Rare Earth elements during the pilot project!

Contents

Material Bins	2
Rare Earth Single Magnet	2
Rare Earth Double Magnet	3
18" Drum Magnet.....	3
Drying Ovens & Kiln	4
Portable Stairs	4
Wifley Table & Feeder	5
18" Sweeco Screener.....	6
Scales.....	6

“This set-up is advantageous for anyone interested in pursuing the mineral/sands business, and can be configured to suit”

Cantilever RE Roll *

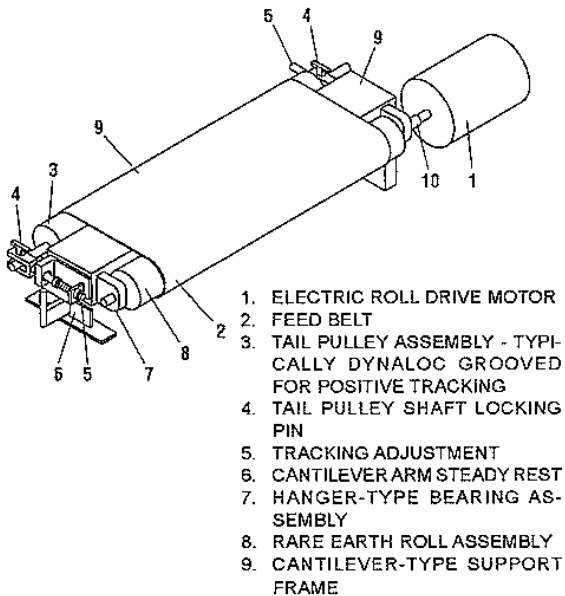

**Eriez Rare Earth Single Magnet w/Mobile Operating Stand \$100,000 (1)
Eriez Rare Earth Single Magnet w/o stand \$50,000 (1)**

- Model #RE—60 -1 Style: 9978098 (1-Freestanding)
- 4 “ diameter Roll X 60” wide
- 21,000 Gauss*
- 10:1 Ratio Gear Box, Input HP 1.30
- VFD - 2 Hp (on stand and w/o)
- Belt Drive
- 3 phase power, 60 Hz, 230/460 Volts, 28/14 amps
- Mounted Controls
- Handles a wide range of particle sizes
- Attracts very fine (minus 325 mesh) materials

**Eriez MMPB-730M p.2*



Eriez 18" Drum Magnet

(1) \$15,000

- Model: 15 X 18 Wet Drum
- Mounted on Dry Stand
- Dry Stand: Mobile
- Eriez Vibratory Feeder
- 4' X 8' X 6" tall
- 1 hp Right Angle Drive
- Forklift Pockets
- 8" Butterfly Valve
- Includes 3 Mobile Feed Bins
- Includes Wet & Dry Stands

Eriez Rare Earth Double Magnet w/Mobile Operating Stand \$175,000 ea. (2 total)

- Model #RE—60 —2 Style: 9978097 (1-Freestanding)
- 4" diameter Roll X 60 " wide
- 21,000 Gauss*
- 10:1 Ratio Gear Box, Input HP 1.30
- VFD—5 HP motor drive each magnet, 1725 rpm can vary speed from 0 to 3600 rpm
- Belt Drive
- 3 phase power, 60 Hz, 230/460 Volts, 28/14 amps
- Mounted Controls
- Compact Modular Design
- Handles a wide range of particle sizes
- Attracts very fine (minus 325 mesh) materials
- Powder Coated
- Includes 60" Feeder System w/Reliance 1 Hp motor
- Stands 36" above ground

*Eriez MMPB-730M p.2

